

Schieberhaltevorrichtungen

Slide holding devices

Verrous de tiroirs

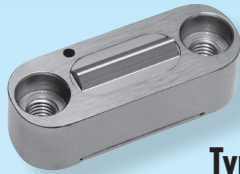

Type 0

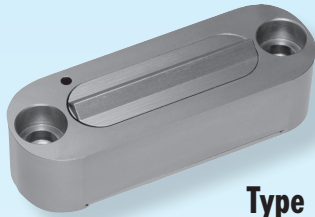

Type 1

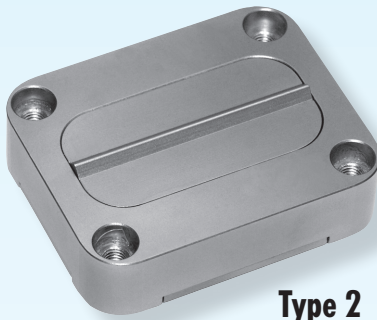

Type 2

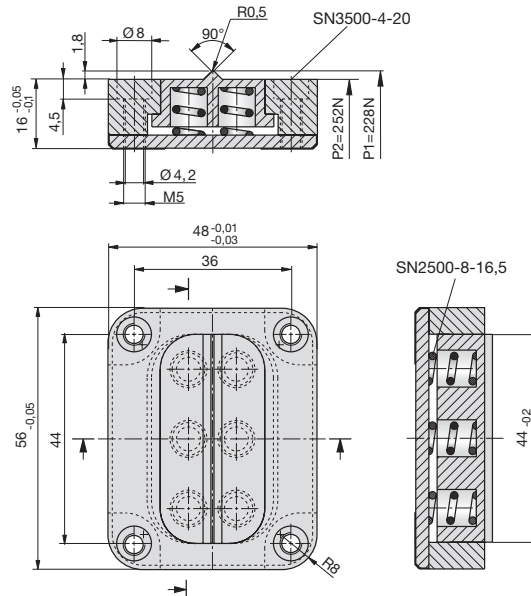
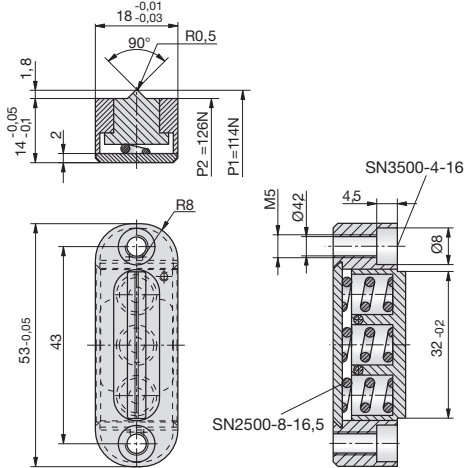
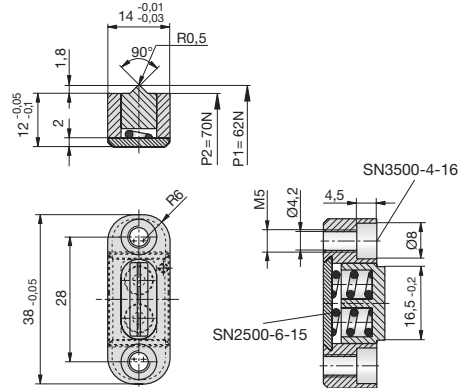

5

Z5140-

Mat.: ST/~52HRC
max. 100 °C

Z5140-Type



Type

0

1

2

Schieberhaltevorrichtungen

Slide holding devices

Verrous de tiroirs



Type 3



Type 4

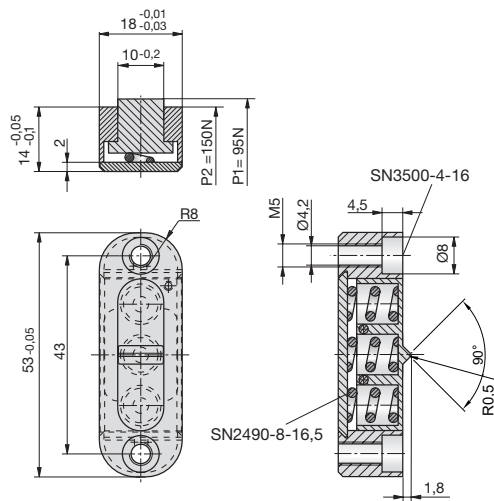
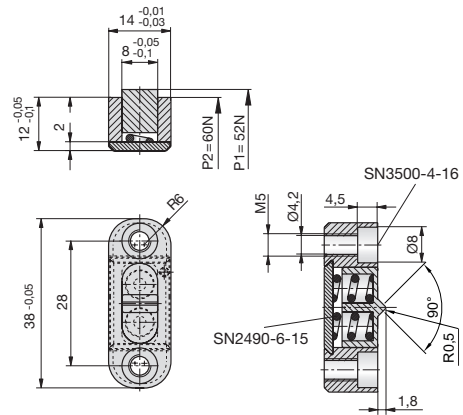

5

Z5140-

Mat.: ST/~52HRC
max. 250 °C

 Z5140-Type



Type

3

4

