

Spiralkern zweigängig für Auswerfer



Z7778-

Mat.: PA
max. 135 °C



Z7778-D-L-D3-D1



Spiral core double-start for ejector

Noyau spiralé à deux filets pour éjecteur

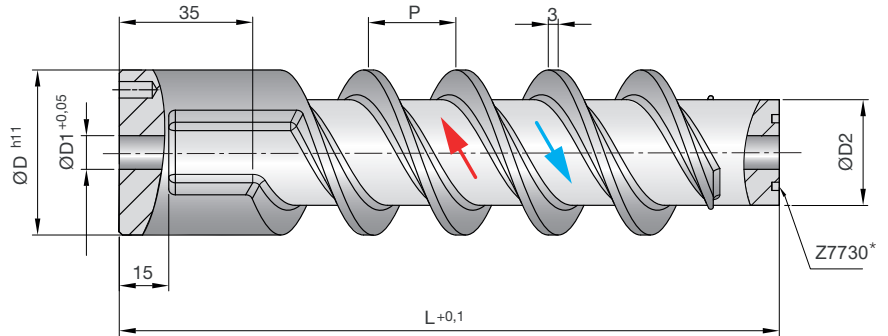

*nicht im Lieferumfang enthalten
not included in the scope of delivery
non inclus dans la livraison

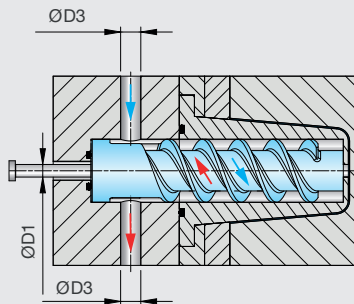

- 3D gedruckter Kühlkern flexibel an Konstruktion anpassbar
- Mit integrierter Auswerferbohrung andere Durchmesser, Längen und Ausführungen kurzfristig lieferbar
- Keine Druckverluste durch Querschnittsänderung (rheologisch ausgelegt)
- 3D printed cooling core flexibly adaptable to design
- With integrated ejector hole other diameters, lengths and designs available at short notice
- No pressure loss due to change in cross-section (rheologically designed)
- Noyau de refroidissement imprimé en 3D adaptable de manière flexible à la construction
- Avec trou d'éjection intégré autres diamètres, longueurs et versions disponibles à court terme
- Pas de perte de pression due à un changement de section (conçu rhéologiquement)

D	L	D3	D1	D2	P	Z7730	D	L	D3	D1	D2	P	Z7730
25	125	6	5	15	20	7,5-1,5	32	250	10	8	22	27	12-2
25	150	6	5	15	20	7,5-1,5	32	125	12	8	22	27	12-2
25	175	6	5	15	20	7,5-1,5	32	150	12	8	22	27	12-2
25	200	6	5	15	20	7,5-1,5	32	175	12	8	22	27	12-2
25	250	6	5	15	20	7,5-1,5	32	200	12	8	22	27	12-2
25	125	8	5	15	20	7,5-1,5	32	250	12	8	22	27	12-2
25	150	8	5	15	20	7,5-1,5	40	125	10	10	26	26	15-2,5
25	175	8	5	15	20	7,5-1,5	40	150	10	10	26	26	15-2,5
25	200	8	5	15	20	7,5-1,5	40	175	10	10	26	26	15-2,5
25	250	8	5	15	20	7,5-1,5	40	200	10	10	26	26	15-2,5
25	125	10	5	15	20	7,5-1,5	40	250	10	10	26	27	15-2,5
25	150	10	5	15	20	7,5-1,5	40	125	12	10	26	26	15-2,5
25	175	10	5	15	20	7,5-1,5	40	150	12	10	26	26	15-2,5
25	200	10	5	15	20	7,5-1,5	40	175	12	10	26	26	15-2,5
25	250	10	5	15	20	7,5-1,5	40	200	12	10	26	26	15-2,5
32	125	8	8	22	27	12-2	40	250	12	10	26	27	15-2,5
32	150	8	8	22	27	12-2	40	125	14	10	26	26	15-2,5
32	175	8	8	22	27	12-2	40	150	14	10	26	26	15-2,5
32	200	8	8	22	27	12-2	40	175	14	10	26	26	15-2,5
32	250	8	8	22	27	12-2	40	200	14	10	26	26	15-2,5
32	200	10	8	22	27	12-2	40	250	14	10	26	27	15-2,5
32	250	10	8	22	27	12-2	50	125	12	10	32	27	18-2,5
32	125	12	8	22	27	12-2	50	150	12	10	32	27	18-2,5
32	200	10	8	22	27	12-2	50	175	12	10	32	27	18-2,5

Z7778-



D	L	D3	D1	D2	P	Z7730	D	L	D3	D1	D2	P	Z7730
50	200	12	10	32	27	18-2,5	60	150	16	10	42	28	26-3
50	250	12	10	32	27	18-2,5	60	175	16	10	42	28	26-3
50	125	14	10	32	27	18-2,5	60	200	16	10	42	28	26-3
50	150	14	10	32	27	18-2,5	60	250	16	10	42	28	26-3
50	175	14	10	32	27	18-2,5	80	150	12	10	55	31	26-3
50	200	14	10	32	27	18-2,5	80	175	12	10	55	31	26-3
50	250	14	10	32	27	18-2,5	80	200	12	10	55	31	26-3
50	125	16	10	32	27	18-2,5	80	250	12	10	55	31	26-3
50	150	16	10	32	27	18-2,5	80	150	14	10	55	31	26-3
50	175	16	10	32	27	18-2,5	80	175	14	10	55	31	26-3
50	200	16	10	32	27	18-2,5	80	200	14	10	55	31	26-3
50	250	16	10	32	27	18-2,5	80	250	14	10	55	31	26-3
60	150	12	10	42	28	26-3	80	150	16	10	55	31	26-3
60	175	12	10	42	28	26-3	80	175	16	10	55	31	26-3
60	200	12	10	42	28	26-3	80	200	16	10	55	31	26-3
60	250	12	10	42	28	26-3	80	250	16	10	55	31	26-3
60	150	14	10	42	28	26-3	80	150	20	10	55	31	26-3
60	175	14	10	42	28	26-3	80	175	20	10	55	31	26-3
60	200	14	10	42	28	26-3	80	200	20	10	55	31	26-3
60	250	14	10	42	28	26-3	80	250	20	10	55	31	26-3