

Spiralkern eingängig

Spiral core single

Noyau spiralé simple passage

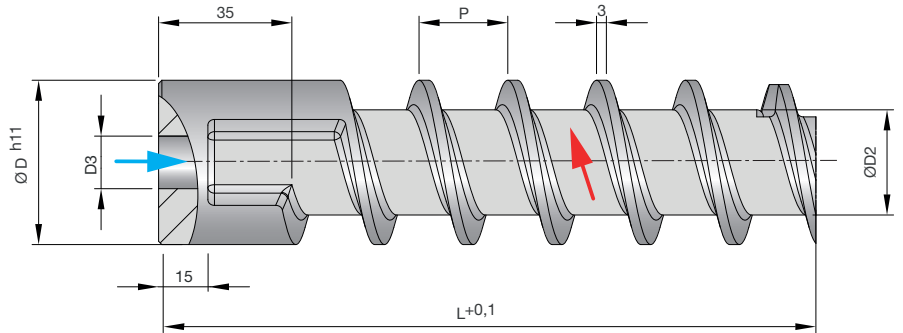
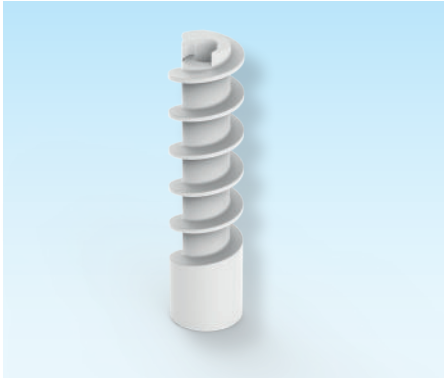

Z7776-

Mat.: PA
max. 135 °C

 Z7776-D-L-D3

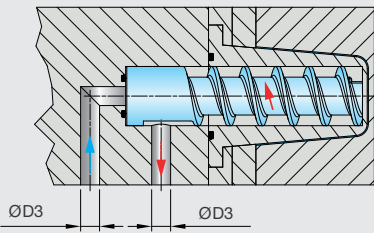

- 3D gedruckter Kühlkern flexibel an Konstruktion anpassbar
- Andere Durchmesser, Längen und Ausführungen kurzfristig lieferbar
- Keine Druckverluste durch Querschnittsänderung (rheologisch ausgelegt)
- 3D printed cooling core flexibly adaptable to design
- Other diameters, lengths and designs available at short notice
- No pressure loss due to change in cross-section (rheologically designed)
- Noyau de refroidissement imprimé en 3D adaptable de manière flexible à la construction
- Autres diamètres, longueurs et exécutions livrables à court terme
- Pas de perte de pression due à un changement de section (conçu rhéologiquement)

D	L	D3	D2	P	D	L	D3	D2	P
12	125	5	8	13	20	250	6	13	18
12	150	5	8	13	20	125	8	13	18
12	175	5	8	13	20	150	8	13	18
12	200	5	8	13	20	175	8	13	18
12	250	5	8	13	20	200	8	13	18
16	125	5	11	14	20	250	8	13	18
16	150	5	11	14	25	125	6	15	20
16	175	5	11	14	25	150	6	15	20
16	200	5	11	14	25	175	6	15	20
16	250	5	11	14	25	200	6	15	20
16	125	6	11	14	25	250	6	15	20
16	150	6	11	14	25	125	8	15	20
16	175	6	11	14	25	150	8	15	20
16	200	6	11	14	25	175	8	15	20
16	250	6	11	14	25	200	8	15	20
20	125	5	13	18	25	250	8	15	20
20	150	5	13	18	25	125	10	15	20
20	175	5	13	18	25	150	10	15	20
20	200	5	13	18	25	175	10	15	20
20	250	5	13	18	25	200	10	15	20
20	125	6	13	18	25	250	10	15	20
20	150	6	13	18	32	125	8	22	27
20	175	6	13	18	32	150	8	22	27
20	200	6	13	18	32	175	8	22	27

Z7776-



D	L	D3	D2	P	D	L	D3	D2	P
32	200	8	22	27	50	200	16	32	27
32	250	8	22	27	50	250	16	32	27
32	125	10	22	27	60	150	12	42	28
32	150	10	22	27	60	175	12	42	28
32	175	10	22	27	60	200	12	42	28
32	200	10	22	27	60	250	12	42	28
32	250	10	22	27	60	150	14	42	28
32	125	12	22	27	60	175	14	42	28
32	150	12	22	27	60	200	14	42	28
32	175	12	22	27	60	250	14	42	28
32	200	12	22	27	60	150	16	42	28
32	250	12	22	27	60	175	16	42	28
40	125	10	26	26	60	200	16	42	28
40	150	10	26	26	60	250	16	42	28
40	175	10	26	26	80	150	12	55	31
40	200	10	26	26	80	175	12	55	31
40	250	10	26	27	80	200	12	55	31
40	125	12	26	26	80	250	12	55	31
40	150	12	26	26	80	150	14	55	31
40	175	12	26	26	80	175	14	55	31
40	200	12	26	26	80	200	14	55	31
40	250	12	26	27	80	250	14	55	31
40	125	14	26	26	80	150	16	55	31
40	150	14	26	26	80	175	16	55	31
40	175	14	26	26	80	200	16	55	31
40	200	14	26	26	80	250	16	55	31
40	250	14	26	27	80	150	20	55	31
50	125	12	32	27	80	175	20	55	31
50	150	12	32	27	80	200	20	55	31
50	175	12	32	27	80	250	20	55	31
50	200	12	32	27					
50	250	12	32	27					
50	125	14	32	27					
50	150	14	32	27					
50	175	14	32	27					
50	200	14	32	27					
50	250	14	32	27					
50	125	16	32	27					
50	150	16	32	27					
50	175	16	32	27					